

Good  
Vibrations

**TARNOS**

***Electromagnetic Vibrating Feeders  
Heavy-Duty***

**The leading brand in vibration**



Manufacturing Licences

**FMC**  
Syntron®



## Models

The range of heavy-duty Electromagnetic Vibrating Feeders features twelve models covering all flow-rate needs from 50 to 1.600 tons per hour. Each model can take a number of trough sizes and shapes.

## Bulk material feeding

### Operating Principle

**The TARNOS Electromagnetic Feeders for Light Capacity work are ideal for feeding bulk materials and parts..**

The operating principle of the Electromagnetic Feeders is based on a system of two masses that are elastically coupled. One of them, the moving mass, is the trough itself (1). The other, the fixed mass, is a strong cast part (2) housing the exciter coil and its magnetic circuit. These masses are coupled by highly elastic steel leaf springs (3). The nearly sine, up-and-down vibrating action of the trough is transmitted to the material, making it move.

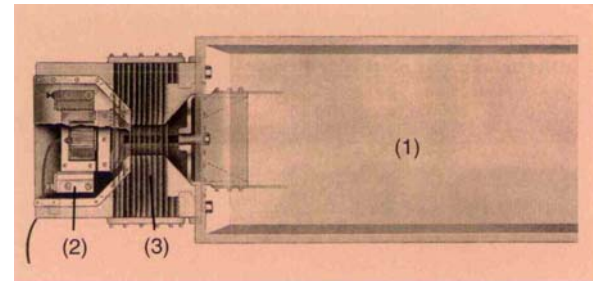

That movement is repeated 3.000 times per minute at 50 Hz.

### Controllers

The Control units for the Electromagnetic Vibrating Feeders control and regulate the material flow, keeping constant the amplitude (vibration or stroke) at the desired value. They work by rectifying single-phase alternating current by means of thyristor or silicon rectifier depending on the type of controller, and regulating the current going to the drive.

The "RSC" control, which rectifies the current by means of thyristor and printed circuit board, enables greater precision to be achieved, and assures steady vibration amplitude, even with voltage fluctuations of between -5 and +5%.

A wide range of additional functions is also available:

- Two speed control
- Responding to external DC signals (from scales, crushing machines, etc.)

## Hopper Desing

The right design in the hopper is needed to achieve good material flow and to choose the feeder giving the best return on the investment. The characteristics of the materials handled, such as their particle size, density and humidity, are important in choosing the feeder and the hopper configuration.

The figure shows the recommended hopper design:

- A: Real wall angle: 60° or more.
- B: Front wall angle: 5° less than "A"
- H: The height between the front outlet of the hopper (gate opening) and the bottom of the trough must be at least twice the largest particle of material, and between 1.2 and 1.5 times the material depth required for discharge, in order to achieve the desired flow rate.
- T: The optimum proportion is for "T" to be equal to or slightly larger than "H / 2". If "T > H", the result is a non-uniform flow of material.

- D: Hopper opening width: 2.5 times the largest particle for random size material, and 5 times largest particle size for sized material

The trough length should be long enough to retain the material when the feeder is stopped.

Drives design enables to withstand massive headloads.

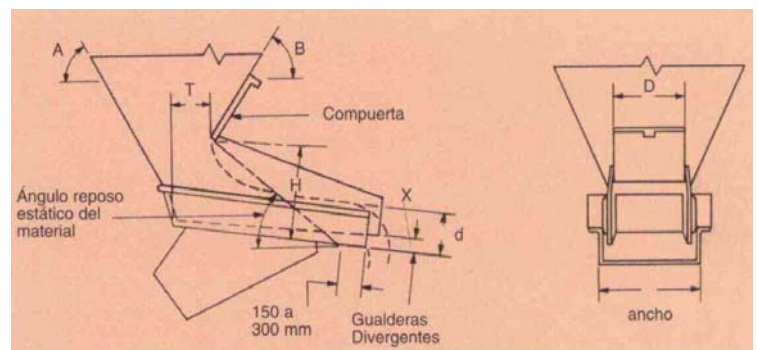

## Trough Models

The standard Electromagnetic Feeders are furnished with open trough made of carbon steel with unions made by electric welding.

As an option, troughs made of special steels can be supplied, or ones lined with wear-resistant, refractory or plastic coatings.

The troughs can be manufactured in many shapes:

- Tubular.
- Closed.
- Stepped.
- Grizzly bar trough

- Flat bottom
- Straight or diagonal discharge, or with tapered walls.

## Features and Advantages

- Ruggedly constructed
- Long service life
- High reliability
- No lubrication needed
- Highly versatile
- Minimal maintenance



## Specifications and dimensions (mm.)

Model	Standard trough (mm)	Flow Rate. (TPH) •	Weight (Kg) □	Power (W)	Current Input (Amp.) *
F-22	355 x 915	70	190	250	2,5
FH-22	457 x 1.070	120	210	250	5
F-220	457 x 760	100	195	450	6
F-280	510 x 915	135	215	550	7
F-330	610 x 1.220	235	450	950	15
F-380	760 x 1.220	300	560	1.250	20
F-440	915 x 1.370	475	1.050	2.200	22
F-450	1.220 x 1.525	700	1.430	2.350	28
F-480	1.220 x 1.830	860	1.870	3.300	35
F-560	1.370 x 2.135	1.200	3.180	2.900	30
F-660	1.525 x 2.285	1.400	3.650	3.300	35
F-88	1.830 x 2.440	1.600	4.730	4.600	60

\* 380 V 50 Hz

• Based on dry sand with a density of 1,6 T/m<sup>3</sup>

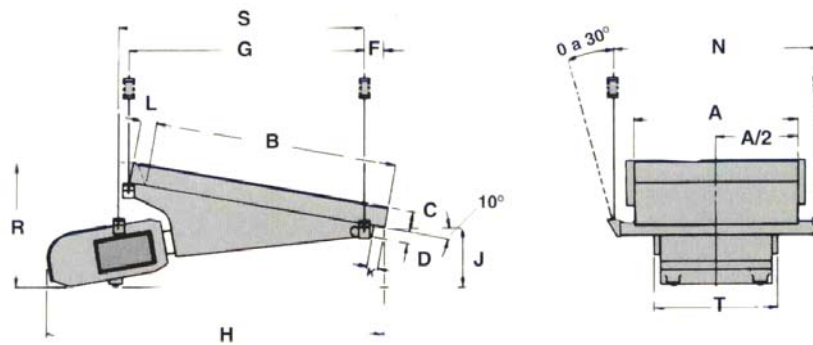

Model	A	B	C	D	F	G	H	J	K	L	N*	N*	R	S	T
F-22	355	910	127	50	105		1.360	270	76	100	430	575	570	1.027	430
FH-22	457	1.66	127	50	92	1.040	1.380	265	63	100	670	670	595		430
F-220	457	760	127	50	92		1.270	285	63	100	430	670	570	950	430
F-280	508	910	127	50	92	890	1.300	280	63	100	720	720	583		430
F-330	610	1.220	127	76	120		1.800	333	90	120	570	865	695	1.325	560
F-380	762	1.220	127	76	130		1.800	366	90	120	620	1.020	710	1.310	560
F-440	910	1.370	152	76	157		2.130	436	115	145	925	1.235	854	1.500	840
F-450	1.220	1.524	152	76	150	1.470	2.220	478	100	145	1.540	1.540	920		840
F-480	1.220	1.828	152	100	160	1.760	2.440	457	115	145	1.550	1.680	955		840
F-560	1.371	2.133	152	100	160	2.060	2.960	625	115	145	1.775	1.775	1.775		840
F-660	1.524	2.286	152	127	175		3.190	615	127	160	1.445	1.965	1.200	2.420	1.250
F-88	1.828	2.438	152	127	187		3.365	645	140	160	1.445	2.285	1.254	2.540	1.285

\* Loading area suspensions.

• Discharge area suspensions.

CAUTION: These units are to be installed, operated and maintained in accordance with accompanying service instructions. Failure to follow these instructions may result in harm to people and/or things.

**TARNOS**

C/ Sierra de Gata, 23

Polígono Industrial San Fernando II

28830 San Fernando de Henares, Madrid (España)

Teléfono: (34) 916564112

Fax: (34) 916765285

<http://www.tarnos.com>

e-mail: [tarnos@tarnos.com](mailto:tarnos@tarnos.com)

The characteristics stated in this catalogue may be changed by TARNOS without prior notice.

VIBRATORS - FEEDERS - SCREENS - VIBRATING SIEVES - CONVEYORS - SPIRAL FEEDERS - FOUNDRY SHAKEOUTS - FLOW SWITCHES - BIN  
VIBRATORS - VIBRATING TABLES - AUTOMATIC PARTS FEEDERS - DOSING EQUIPMENT - TRAVELLING WATER SCREENS